

“Tech Talk”



Reintroducing the Fill-Vent Valve (RPI Part #RCV052)

We are very pleased to announce the reintroduction of the manual Fill-Vent Valve Assembly to fit the Ritter• Midmark 7 and M7 series autoclaves.

The original RPI Part #RCV052 has been carried over to this second generation. Its sleek new body style is supplied with the male connector fittings for your convenience and ease of installation. The body is brass and includes EP seals.

The Valve Assembly fits these models: M7 (011 Serial #'s MH3105 thru present and V2200 thru present; M7 (012) Serial #'s MJ1242 thru present and V2200 thru present; M7 (014) Serial #'s ML4210 thru present and V2200 thru present; and, M7 (013/015/016) all Serial #'s.

As always, RPI supplies a Valve Stem Repair Kit for this valve assembly, just ask for RPI Part #RCS098 or you can simply order the o-rings (RPI Part #'s RPO306 and RPO307), or the Lubricant (RPI Part #RPL090) and rebuild the valve stems yourself. By the way, this kit also fits the original forged valve used by Wilmot Castle in the Model 7 sterilizer as well as the current Midmark valve.

If you need the Valve Stem Repair Kit for the original forged valve that RPI previously sold and obsoleted in 1999, we still offer the kit with the stem and o-rings as a rebuild option. Just ask for RPI Part #RCS097.

SERVICE TIP

WHAT IF I WANT TO REBUILD THE VALVE, WHICH KIT DO I NEED?

If you want to rebuild the Fill-Vent Valve, here's how to tell which rebuild kit you will need:

- If your valve and stem look like the ones in **Figure A**, and the stem includes (2) different sized o-rings, then you need the Valve Stem Repair Kit (RPI Part #RCS098).
- If your valve and stem look like the ones in **Figure B**, and the stem includes (2) of the same sized o-rings, then you need Valve Stem Repair Kit (RPI Part #RCS097).

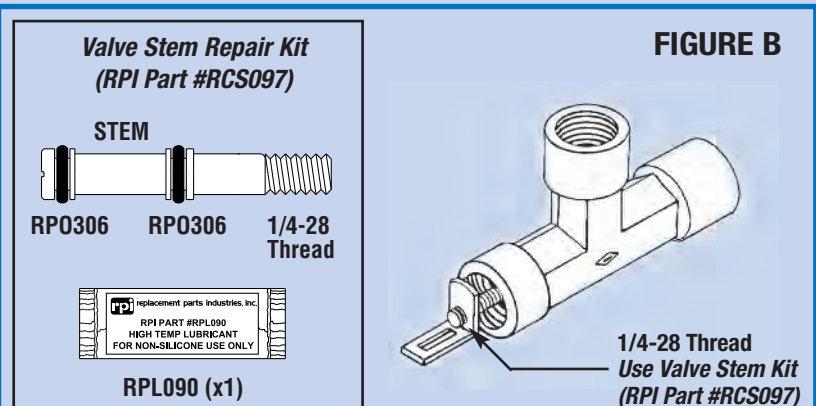
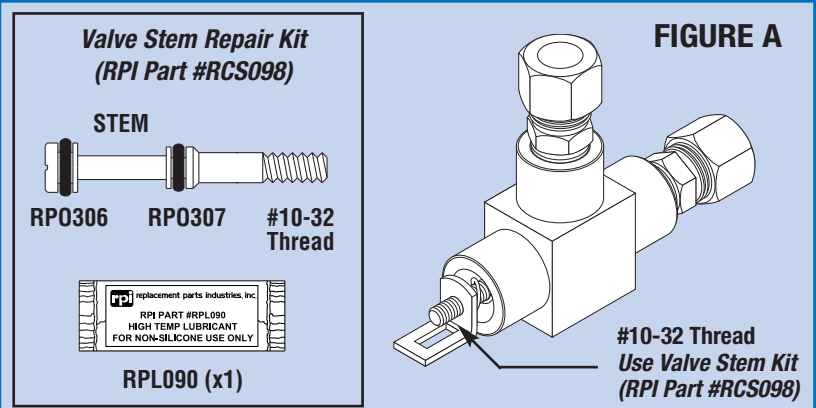

As featured in *the Alternate Source*® December 1999; Volume 5, No. 6

Article was updated 09/09 due to the re-release of the new Fill-Vent Valve (RPI Part #RCV052)



replacement parts industries, inc.

20338 Corisco Street • Chatsworth, California • 91311

Call (800) 221-9723 • Fax (818) 882-7028 • Email www.order@rpi.com