



Healthcare Components Group

CALL: 800-221-9723 or 818-882-8611 • E-MAIL: techsupport@rpiparts.com

WEBSITE: www.healthcarecomponents.com • www.rpiparts.com

Read and save these instructions!

WATER-MIZER[®]

**Water saving & tempering device
for sterilization equipment**

HCG/RPI Part #RPA466

Installation, operation and maintenance manual

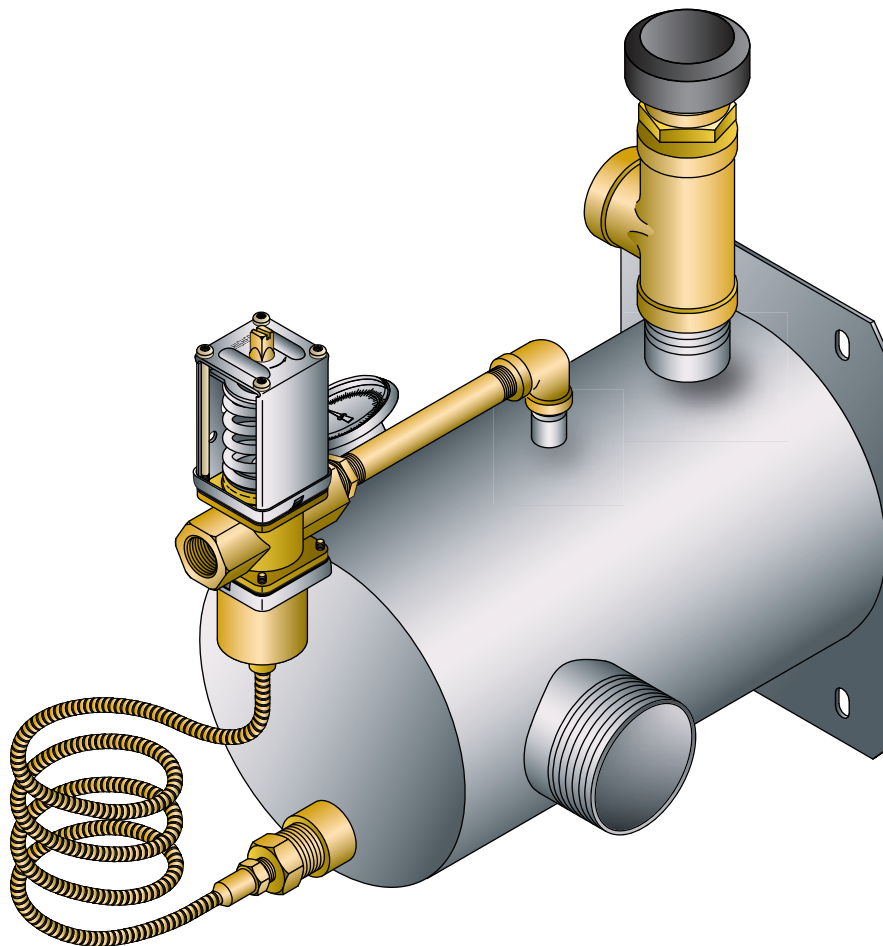

PLEASE: read this manual!

This manual will guide you through installation, operation and maintenance procedures for your new WATER-MIZER. Proper installation and operating practices will ensure years of trouble-free service.

Technical support: (800) 221-9723 x135

If you have questions, review the troubleshooting guide on Page 7. If you still have questions, call our technical support group at (800) 221-9723 x135. Technicians are available from 8:00 a.m. to 4:30 p.m. (Pacific Time) Monday through Friday, excluding major holidays.

For information about other RPI parts, please contact us:

Replacement Parts Industries, Inc.
625 Cochran Street • Simi Valley, CA 93065
Telephone: (800) 221-9723 or (818) 882-8611
Fax: (818) 882-7028
E-mail: order@rpiparts.com
Website: www.rpiparts.com

08-31-09 Water-Mizer® Patent Official: 7, 578,967

Water-Mizer is a registered trademark of its respective holder.

WATER-MIZER® table of contents.

Product overview

Features summary 1
Dimensions 2
Warranty 9

Installation

Installation instructions 3
Mounting 4

Operation

Start-up and operation instructions 5

Maintenance

Maintenance instructions 6
Troubleshooting guide 7
Replacement parts 8

WATER-MIZER® features summary.

Cool discharged hot water

The WATER-MIZER is a water saving and tempering device that efficiently mixes cold water with steam condensate discharged from sterilization equipment, such as a steam sterilizer, to reduce the discharged water temperature before it enters a municipal sewer system.

There are two reasons to use a water tempering device. First, most municipalities prohibit draining water hotter than 140°F (60°C) into their sewer systems. And second, PVC drain pipes are susceptible to damage from water that is too hot. When faced with either of these situations, the WATER-MIZER is the solution!

Most steam sterilizers use continuous cold water to temper the steam condensate, which is wasteful. The WATER-MIZER monitors the drain temperature and applies cold water only when needed!

Horizontal design!

WATER-MIZER's space-efficient horizontal orientation and side drain outlet provide enough clearance to allow it to be mounted directly underneath most steam sterilizers, saving footprint space while allowing room for pitched drain piping.

How it works: Hot + cold = tempered!

- 1** Steam condensate discharged from your sterilization equipment enters the WATER-MIZER through piping connected to the top threaded connection. A vacuum breaker prevents backflow into potable water systems.
- 2** Cold water enters through the temperature-actuated valve. The valve and the WATER-MIZER's straight forward design ensure efficient mixing of hot and cold water. The valve's sensor, located near the outlet, ensures that water leaving the WATER-MIZER is 140°F (60°C) or less before entering the municipal sewer system.
- 3** Tempered water at 140°F (60°C) or less exits through the side outlet for safe discharge into a municipal sewer system.

Reliable, non-electric valve

The temperature-actuated valve is time-tested to be reliable. And because it is non-electric, no wiring is required!

Built in thermometer

The WATER-MIZER has a built in thermometer for easy calibration and continuous monitoring of effluent temperature

Multiple mounting options

The WATER-MIZER can be mounted by attaching the integral mounting plate directly to the frame of the sterilization equipment or by attaching the mounting plate to an adjustable floor stand. (See Page 8 to order the Adjustable Floor Stand, HCG/RPI Part #RPH470). These multiple mounting options provide capability for the WATER-MIZER to be properly supported and not secured entirely by piping.

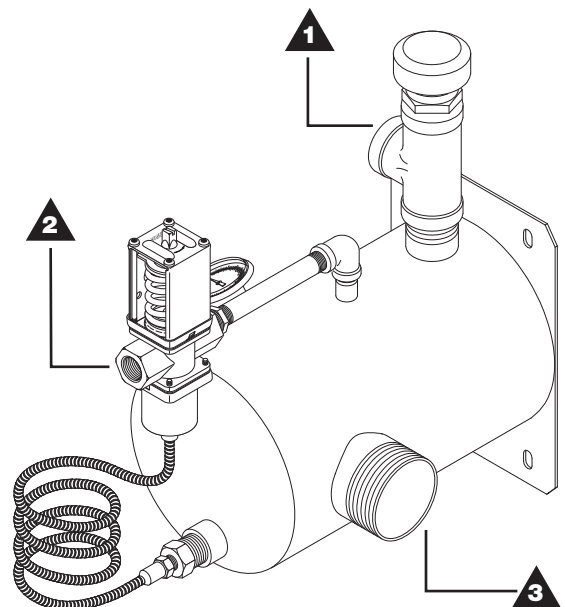

WATER-MIZER® dimensions.

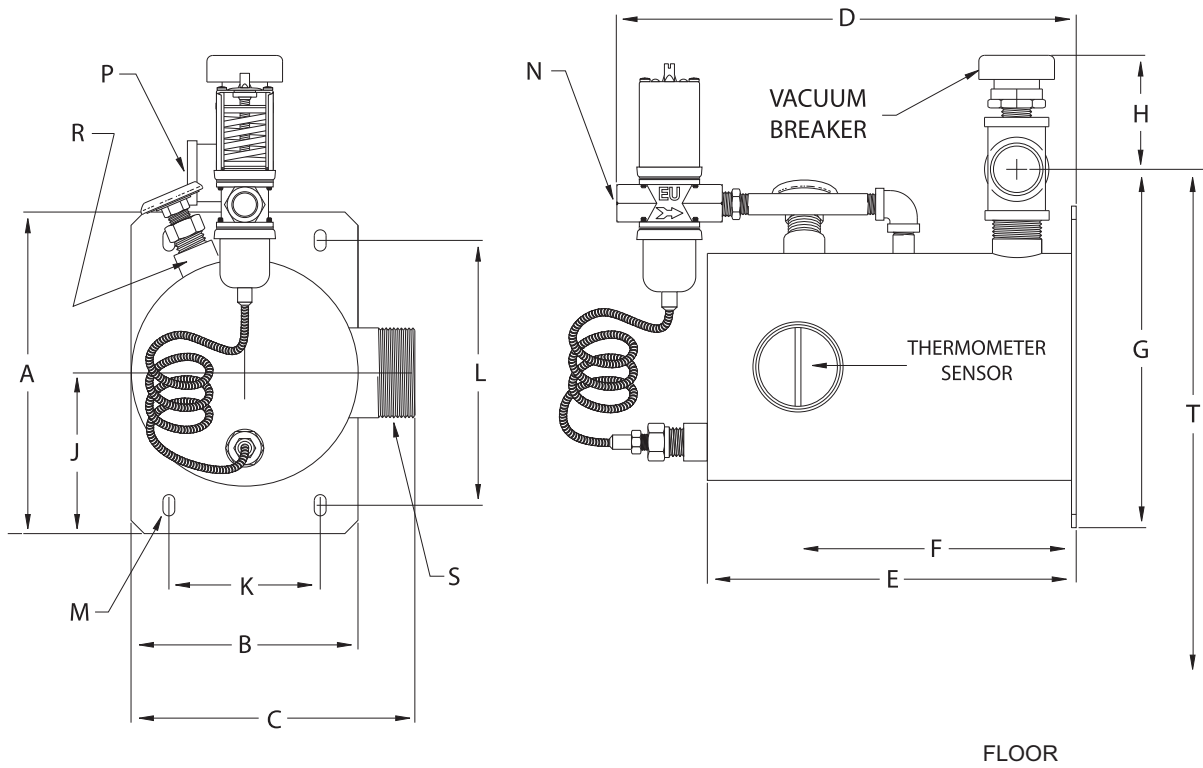

DIMENSIONS

| DIM | DESCRIPTION | INCHES | MM |
|-----|---|----------------------------|----------------------|
| A | HEIGHT OF MOUNTING PLATE | 8-1/2 | 216 |
| B | WIDTH OF MOUNTING PLATE | 6 | 152 |
| C | WIDTH OF MOUNTING PLATE AND TEMPERED WATER OUTLET | 7-1/2 | 191 |
| D | LENGTH FROM COLD WATER INLET VALVE TO MOUNTING PLATE | 12 | 305 |
| E | LENGTH FROM END OF TANK TO MOUNTING PLATE | 9-3/4 | 248 |
| F | LENGTH FROM CENTER OF TEMPERED WATER OUTLET TO MOUNTING PLATE | 7-3/8 | 187 |
| G | HEIGHT FROM BOTTOM OF MOUNTING PLATE TO CENTER OF HOT WATER INLET | 9-1/2 | 241 |
| H | HEIGHT FROM CENTER OF HOT WATER INLET TO TOP OF VACUUM BREAKER | 3 | 76 |
| J | HEIGHT FROM BOTTOM OF MOUNTING PLATE TO CENTER OF TEMPERED WATER OUTLET | 4-1/4 | 108 |
| K | WIDTH OF MOUNTING PLATE HOLES, CENTER TO CENTER | 4 | 102 |
| L | DISTANCE BETWEEN MOUNTING HOLES, CENTER TO CENTER | 7 | 17 |
| M | MOUNTING HOLE | 5/16 | 8 |
| N | COLD WATER INLET PORT SIZE | 3/8" FPT | N/A |
| P | HOT WATER INLET PORT SIZE | 1" FPT | N/A |
| R | AUXILIARY PORT SIZE | 1/2" FPT | N/A |
| S | TEMPERED WATER OUTLET PORT SIZE | 2" MPT | N/A |
| T | HEIGHT WITH FLOOR STAND (FROM FLOOR TO CENTER OF HOT WATER INLET - 1" [25 MM] INCREMENTS) | MIN. 10-1/4 TO MAX. 22-1/4 | MIN. 260 TO MAX. 565 |

Letters not uses: I, O & Q

Installation checklist.

Step-by-step installation instructions

- ❑ Turn off steam supply to sterilizer and wait until jacket and chamber pressure is 0 psi.
- ❑ Note that there are three connections to be made to the WATER-MIZER:
 - Cold water inlet
 - Hot water inlet
 - Tempered water outlet to drain
- ❑ Position the WATER-MIZER to allow the most direct path of piping to minimize fittings.
- ❑ Mount the WATER-MIZER by attaching the mounting plate to the adjustable floor stand (see page 8 to order the Adjustable Floor Stand, RPI Part #RPH470), or by attaching the WATER-MIZER directly to the frame of the sterilization equipment. See page 4 for mounting options.

DO NOT SUPPORT WATER-MIZER ENTIRELY BY PIPING. MOUNT WATER-MIZER FIRMLY BEFORE PIPING.
- ❑ Position unions on all connections as close to the WATER-MIZER as possible to make cleaning and maintenance easier. (For Maintenance Instructions, see page 6.)
- ❑ Cold water supply connection instructions:
 - Cold water supply connection on valve is 3/8" FPT.
 - Disconnect jacket and chamber trap cooling valves on sterilizer and plug all openings.
 - Verify that the supply water pressure to the valve will be at least 25 psi (172 kPa) and not more than 80 psi (552 kPa).
 - Pipe a 3/8" line directly to the WATER-MIZER from the main water supply line.
 - Install a cold water supply union as close to the WATER-MIZER as possible.
 - Install a cold water shut-off valve before the union in the cold water supply line.

- ❑ Hot water inlet connection instructions:
 - Hot water inlet connection is 1" FPT.
 - Using Teflon® tape or pipe sealant, install brass tee and vacuum breaker assembly provided, to the sterilizer drain inlet on the WATER-MIZER.
 - Locate a union as close to the WATER-MIZER as possible
 - Connect all sterilizer drain lines to 1" pipe and run pipe as directly as possible to the WATER-MIZER. If the piping to the sterilizer drain inlet has a horizontal run, maintain a pitch to the WATER-MIZER of at least 1/8"/ft (1%).

STERILIZER DRAIN LINES MAY BE HOT! USE CAUTION. MAKE SURE STEAM SUPPLY IS SHUT OFF.
- ❑ Tempered water outlet connection instructions:
 - Tempered water outlet connection is 2" MPT.
 - Install a union as close to the WATER-MIZER as possible.
 - Run a 2" pipe as directly as possible from the WATER-MIZER to the drain. Maintain a pitch to drain of at least 1/8"/ft (1%).
 - Make sure there is a 1" (25 mm) air gap between the drain piping and the drain.
- ❑ Fill the WATER-MIZER tank with cold water before initial use. **If the WATER-MIZER is run empty, excessive noise may occur.**
- ❑ Turn on sterilizer and using the built-in thermometer, monitor drain water temperature. Adjust valve on case as indicated to maintain drain temperature below 140°F (60°C).

Mounting options.

Two mounting options

There are two different mounting options available to ensure that the WATER-MIZER will be properly supported and not secured entirely by piping.

Mounting option 1: Sterilizer Frame Mount

Several options exist for mounting WATER-MIZER to a sterilizer's frame, making it the most widely used mounting technique. Mounting the WATER-MIZER to the frame may require that holes be drilled in the frame. Secure WATER-MIZER to the frame of the sterilizer by attaching the integral mounting plate to the frame.

Note: Sterilizer frame mount not illustrated due to differences in framework on differing sterilizers.

Mounting option 2: Floor mount (shown below).

Note: Adjustable floor stand (HCG/RPI Part #RPH470) can be ordered separately (see page 8).

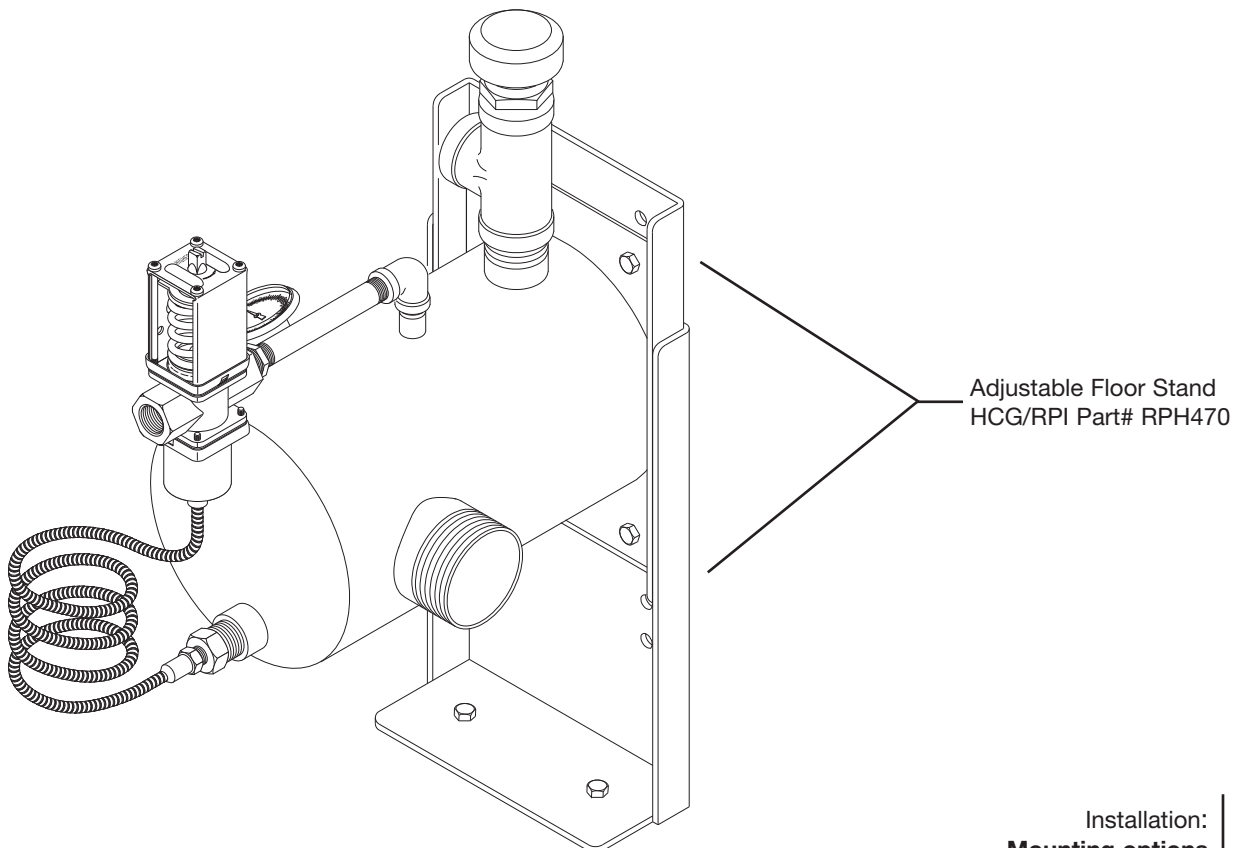

WATER-MIZER® operation.

How to operate

Once properly installed, to operate the WATER-MIZER simply open the cold water supply valve.

Principle of operation

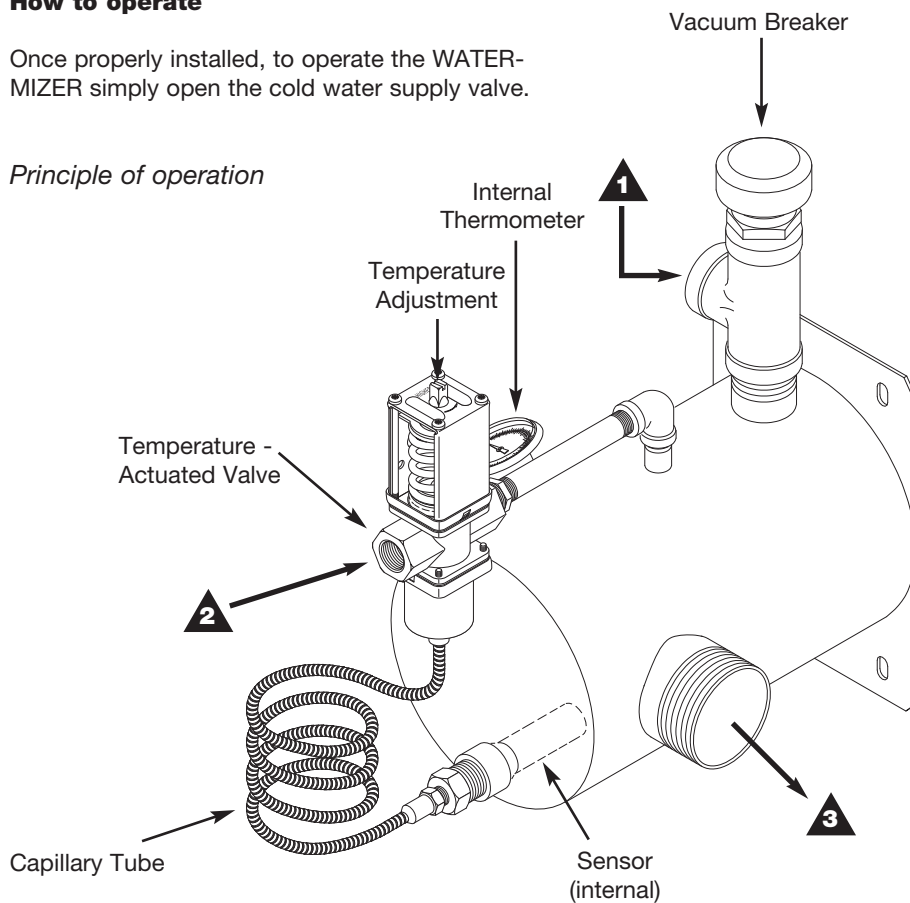

1 Steam condensate discharged from your sterilization equipment enters the WATER-MIZER through piping connected to the top threaded connection. The vacuum breaker prevents backflow into potable water systems.

2 Cold water enters through the temperature actuated valve. The valve and the WATER-MIZER's straight forward design ensure efficient mixing of hot and cold water. The valve's sensor, located inside the chamber near the outlet, ensures that water leaving the WATER-MIZER is less than 140°F (60°C) before entering the municipal sewer system.

3 Tempered water at 140°F (60°C) or less exits through the side outlet for safe discharge into a municipal sewer system or PVC pipe.

WATER-MIZER® maintenance.

Annual preventive maintenance on your WATER-MIZER is recommended.

Step-by-step maintenance instructions

- ❑ Shut off steam supply to sterilizer.
Caution: hot pipes.
- ❑ Shut off cold water supply.
- ❑ Make sure jacket pressure is 0 psi.
- ❑ Disconnect service unions at:
 - Cold water inlet
 - Hot water inlet
 - Tempered water outlet
- ❑ Remove the WATER-MIZER from piping and take to a service sink. Add water and, with pipe caps or hands covering the hot water inlet and tempered water outlet, shake the WATER-MIZER to dislodge mineral deposits. Dump mineral deposits and rinse.
- ❑ If severe mineral accumulation has occurred, remove the split nut holding the sensor in place and remove the thermal sensor from the WATER-MIZER chamber. Gently clean the sensor with an abrasive pad. **Do not twist the capillary tube during removal or cleaning.** Remove the built-in thermometer from the WATER-MIZER. Using an abrasive pad clean any accumulated mineral.
- ❑ Fill the WATER-MIZER with cold water. Reconnect service unions, and open cold water supply valve and steam supply valve to the sterilizer to resume operation. **Do not run the WATER-MIZER dry – excessive noise may occur.**
- ❑ The temperature of the effluent should be checked as part of the current planned maintenance procedures for the sterilizer which it is attached to. The internal thermometer should be checked against a calibrated external thermometer (or temperature probe) annually.

Troubleshooting guide.

| Problem Number | Problem | Problem Cause | Action |
|----------------|---|--|--|
| 1 | Water leaving the WATER-MIZER is hotter than 140°F (60°C) | Mineral accumulation in mixing chamber | Remove the WATER-MIZER and dislodge mineral accumulation. |
| | | Mineral accumulation on thermal sensor | Remove thermal sensor from WATER-MIZER and gently remove mineral accumulation with an abrasive pad. Do not twist capillary tubing during removal or cleaning. |
| | | Cold water valve setting | Valve is not set properly. Adjust valve so drain effluent is below 140°F. |
| | | Cold water supply Less than 25 psi | Turn on cold water supply and make sure cold water is present. |
| | | Valve malfunction | Replace valve or use PM Kit. |
| 2 | Excessive Noise | Steam trap on sterilizer stuck open or defective | Have sterilizer serviced by a qualified technician. |
| | | Dry Water-Mizer | Water-Mizer must be filled with cold water before initial use or before returning sterilizer to service. Continued operation will correct this problem. |
| 3 | Thermometer Not Reading Properly | Mineral Accumulation on thermometer | Remove thermometer from WATER-MIZER and gently remove mineral accumulation with an abrasive pad. |

WATER-MIZER® replacement parts.

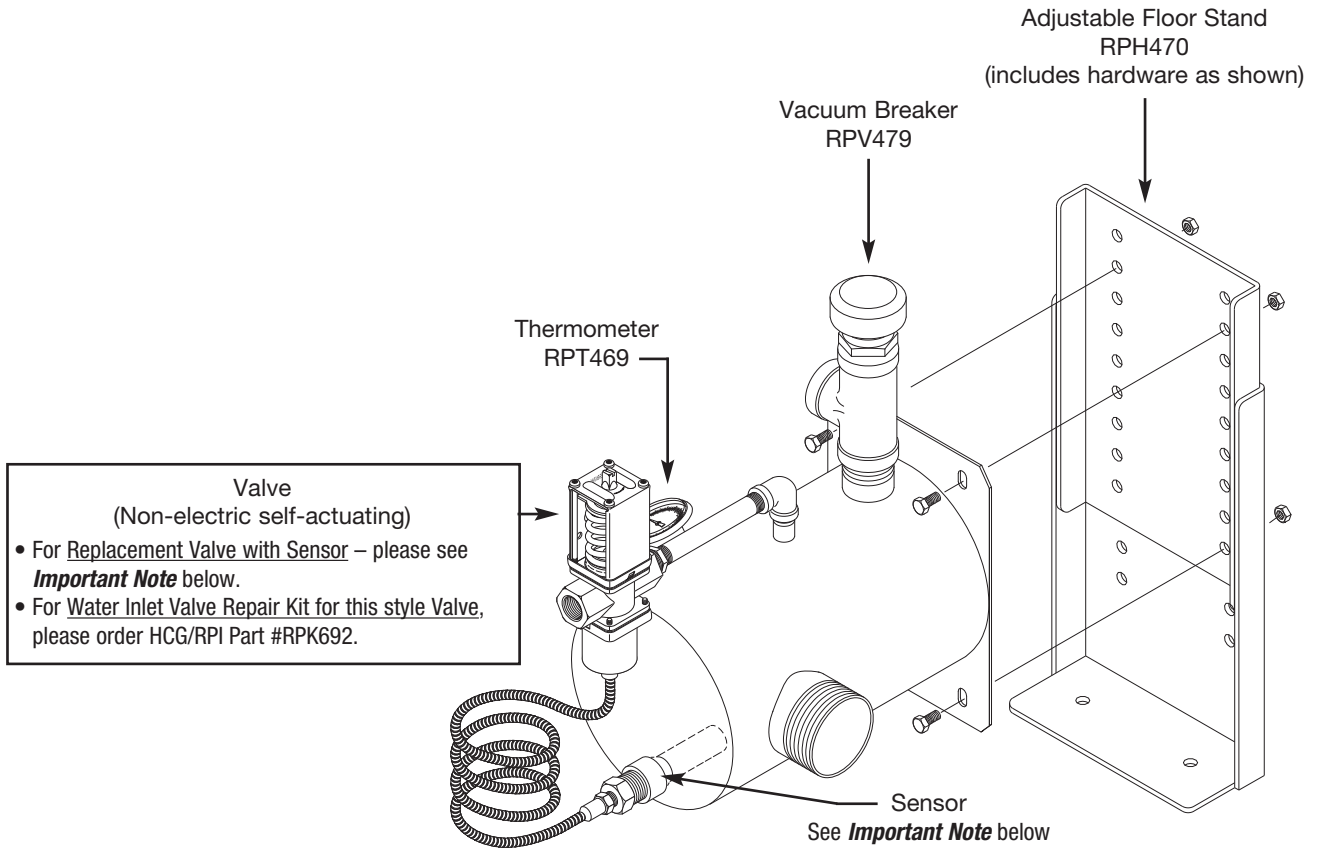

| WATER-MIZER Model JB-01 (HCG/RPI Part #RPA466) Replacement Parts | |
|---|-------------------|
| Description | RPI Part # |
| Water Inlet Valve Repair Kit* | RPK692 |
| Valve – Non-electric self-actuating (See Important Note to the right) | RPV468 |
| Water Inlet Valve Repair Kit* <i>Fits only the RPV468 style Valve</i> (See Important Note to the right) | RPK478 |
| Sensor <i>Fits only the RPV468 style Valve</i> (See Important Note to the right) | RPS475 |
| Adjustable Floor Stand | RPH470 |
| Thermometer | RPT469 |
| Vacuum Breaker | RPV479 |
| * <i>Water Inlet Valve Repair Kits (HCG/RPI Part #'s RPK478 and RPK692) are not shown in the illustration above. Please see RPI Website for illustration and details.</i> | |

Important Note

When ordering a replacement Valve with Sensor, (HCG/RPI Part #RPV468), please note that the replacement valve will look similar to the part shown below. This style Valve has the same fit and function as the valve style shown in the exploded view above.

Also, please note that the Sensor (HCG/RPI Part #RPS475) and a Water Inlet Valve Repair Kit (HCG/RPI Part #RPK478) are available for the Valve shown below.

RPV468

When you order a Replacement Valve with Sensor (HCG/RPI Part #RPV468), you will receive the style shown to the right.

**For your replacement parts needs, RPI has parts to fit various bulk sterilizers.
See the RPI catalog or visit the website at www.rpiparts.com.**

90 Day limited warranty.

Replacement Parts Industries, Inc. (RPI) warrants to the original user that the WATER-MIZER® (RPI Part #RPA466) will be free from defects in materials and workmanship for a period of 90 days after installation.

If the WATER-MIZER is found to be defective in material or workmanship during the applicable warranty period, RPI's entire liability, and the purchaser's sole and exclusive remedy, shall be the repair or replacement of the defective product, or the refund of the purchase price, at RPI's election. RPI shall not be liable for any costs or expenses, whether direct or indirect, associated with the installation, removal or reinstallation of any defective product.

RPI's limited warranty shall not be effective or actionable unless there is compliance with all installation and operating instructions furnished by RPI, or if the product has been modified or altered without the written consent of RPI, or if such product has been subject to accident, misuse, mishandling, tampering, negligence or improper maintenance. Any warranty claim must be submitted to RPI in writing within the stated warranty period.

RPI's limited warranty is made in lieu of, and RPI disclaims all other warranties, whether express or implied, including but not limited to any IMPLIED WARRANTY OF MERCHANTABILITY, ANY IMPLIED WARRANTY OF FITNESS FOR A PARTICULAR PURPOSE, any implied warranty arising out of a course of dealing or of performance, custom or usage of trade.

RPI SHALL NOT, UNDER ANY CIRCUMSTANCES BE LIABLE FOR ANY DIRECT, INDIRECT, INCIDENTAL, SPECIAL OR CONSEQUENTIAL DAMAGES (INCLUDING, BUT NOT LIMITED TO, LOSS OF PROFITS, REVENUE OR BUSINESS) OR DAMAGE OR INJURY TO PERSONS OR PROPERTY IN ANY WAY RELATED TO THE MANUFACTURE OR THE USE OF THIS PRODUCT. The exclusion applies regardless of whether such damages are sought based on breach of warranty, breach of contract, negligence, strict liability in tort, or any other legal theory, even if RPI has notice of the possibility of such damages.

By purchasing this produce, the purchaser agrees to the terms and conditions of this limited warranty.



A Healthcare Components Group company

Replacement Parts Industries, Inc.
625 Cochran Street • Simi Valley, CA 93065
Phone: (800) 221-9723 or (818) 882-8611 • Fax: (818) 882-7028
E-mail: order@rpiparts.com • Website: www.rpiparts.com