



replacement parts industries, inc.

CALL 800-221-9723 or 818-882-8611 • FAX 818-882-7028
E-MAIL: techsupport@rpiparts.com • WEBSITE: www.rpiparts.com

"The Alternate Source"

PCK690 SPRING ARM SPRING & GUIDE ASSEMBLY INSTALLATION INSTRUCTIONS

FOR YOUR SAFETY

Use a Horseshoe Pin (RPI Part #PCP691) to lock the **existing** Spring Arm Spring & Guide Assembly in place before you begin servicing the assembly or replacing the following any of the parts listed to the right.

- Arm Knuckle (RPI Part #PCK645)
- Arm Hinge Pin (RPI Part #PCP662)
- Connector Hinge Pin (RPI Part #PCP663)
- Knuckle and Rod Connector (RPI Part #PCC646)
- Leveling Rod and Nut (RPI Part #PCR699)
- Wire Retainer Assembly (RPI Part #PCA692)

STEP 1: REMOVE FRONT ARM UPPER COVER – SEE FIGURE A.

- Remove Front Arm Cover Screws (RPI Part #RPH233).
- Remove one of the two Counter Balance Spring Cover Inserts. (Depending on the age of the light, the Counter Balance Spring Cover may or may not have these screws.)
- Remove the Counter Balance Spring Cover (RPI Part #PCC664) by sliding it over the Counter Balance Springs (RPI Part #PCS659).
- Remove the Counter Balance Springs.
- Remove the two Spring Retainers with Washers (RPI Part #PCK660).
- Remove Front Arm Upper Cover by lifting upwards.

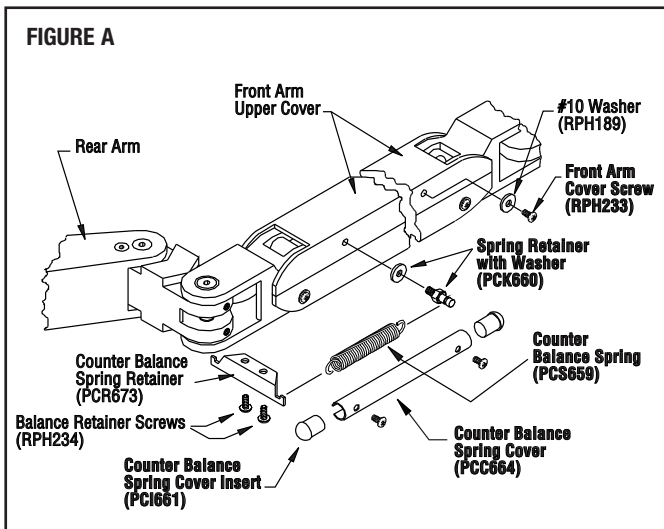

STEP 2: INSTALL HORSESHOE PIN & REMOVE SPRING ARM SPRING & GUIDE ASSEMBLY – SEE FIGURE B.

- Pull front arm down until you can see the spring guide move out through the main spring. Insert the Horseshoe Pin (RPI Part #PCP691) into the spring guide holes (inside the "U" bracket). The spring guide holes must be completely exposed through the "U" bracket to install the Horseshoe Pin. To expose the spring guide holes, turn the adjustment flange nut counter clock-wise using a 1/2" wrench. Do not attempt to remove either of the Connector Hinge Pins until the Horseshoe Pin has been properly installed.
- Support the front arm. Remove the Connector Hinge Pin (RPI Part #PCP663) that is closest to the light head. Remove the Connector Hinge Pin (RPI Part #PCP663) that is closest to the rear arm.

- Remove the existing Spring Arm Spring & Guide Assembly by pulling it through the "U" bracket towards the front of the light head.

STEP 3: INSTALL THE NEW SPRING ARM SPRING GUIDE ASSEMBLY (RPI PART #PCK690)

- Screw the new Knuckle & Rod Connectors (RPI Part #PCC646) on to each end of the leveling rod.
- Loosen the flange nut that is located closest to the Horseshoe Pin until it meets the Knuckle & Rod Connector.
- Slide the new Spring Arm Spring & Guide Assembly through the "U" bracket, Horseshoe Pin end first. Position the Knuckle & Rod Connectors with the through holes in the arm knuckles. Install the new Connector Hinge Pins.

CAUTION: Remove the horseshoe pin only after both Connector Hinge Pins have been installed.

STEP 4: CHECK FOR DRIFTING – SEE FIGURE A.

- Reinstall the Front Arm Upper Cover, the Spring Retainers with Washers and the Counter Balance Springs. It is not necessary to reinstall the Spring Cover and Spring Cover Inserts in order to check for drifts.
- If drifting occurs, remove the Front Arm Upper Cover, the Spring Retainers with Washers and the Counter Balance Springs in order to make adjustments. To adjust for a Down Drift, use a 1/2" wrench to turn the Tension Adjustment Flange Nut counter-clockwise to increase tension. To adjust for an Up Drift turn the Tension Adjustment Flange Nut clockwise to decrease tension. (Several turns may be necessary.)
- It is necessary to check for drifts after each adjustment.

STEP 5: FINAL ASSEMBLY – SEE FIGURE A.

- Slide Counter Balance Spring Covers over the Counter Balance Springs.
- Re-install Counter Balance Spring Cover Inserts.
- Re-install Front Arm Cover Screws with #10 Washers.

FIGURE B

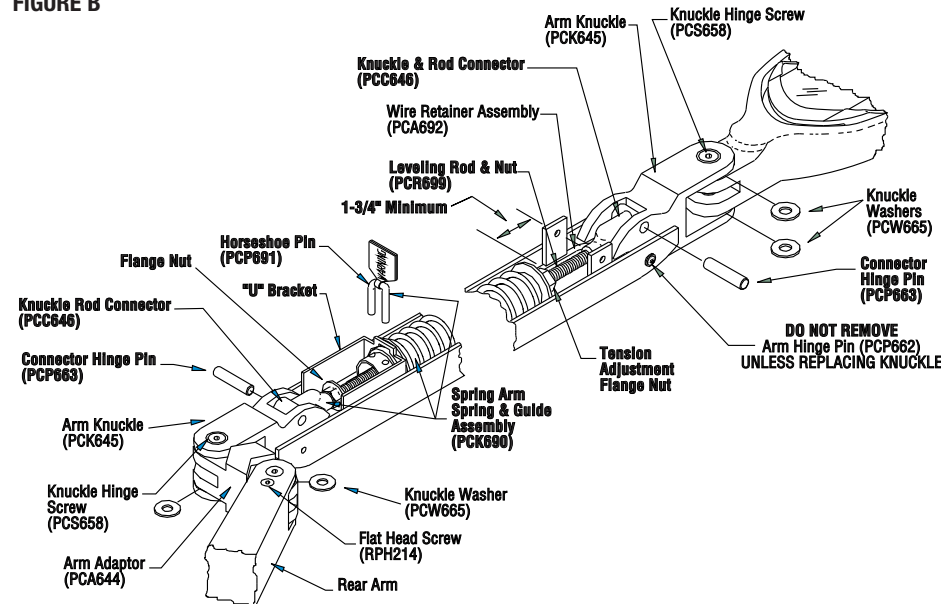

NOTE: Location of Knuckle Washers must be as shown in illustration.