



replacement parts industries, inc.

CALL 800-221-9723 or 818-882-8611 • FAX 818-882-7028
E-MAIL: techsupport@rpiparts.com • WEBSITE: www.rpiparts.com

MTK019 AIR VALVE DIAPHRAGM KIT INSTALLATION INSTRUCTIONS

- 1) Place both of the main modules on their back to have easy access to the valves.
- 2) Disconnect the air hoses leading from the MAC manifold to the pneumatic valve blocks starting with the top and working down. It is **important** to label the air hoses to avoid confusion upon reassembly.
- 3) Remove the (4) screws that hold the pneumatic valve block to the manifold using a 9/64" Allen key and set the screws aside for later use.
- 4) Flip the valve over so the air valve diaphragm is facing up and the pneumatic valve block lays on a flat surface.
- 5) If available, use the Wrench (Low Profile) (RPI Part #RXT003) to slide under the air valve diaphragm and hold the valve shaft in place. **Note:** To allow for a better visual, it may be easier to pull the old air valve diaphragm off the retaining screw. Use a 3/32" Allen key while holding the valve shaft in place to break the center screw loose. If the screw is difficult to loosen, a pair of vice grips may be used on the side of the head of the screw to break the screw free. Do not worry about damage to the screw as new screws are provided in this Kit.
- 6) Once the old screw and air valve diaphragm are removed, clean the valve assembly of any excess Loctite® or debris.
- 7) Place the new air valve diaphragm on the pneumatic valve block with the grooved side facing up. Sparingly apply Retaining Compound 609 (RPI Part #RXA048) to the tip of the Screw (RPI Part #RXH049). Install the screw and tighten until snug. **Caution:** Avoid using a large amount of retaining compound to make removing the screw at the next PM easier. Do not over-tighten the retaining screw, this may cause the seal to cup or deform resulting in an ineffective seal.
- 8) Place the pneumatic valve block on the manifold and hold the pneumatic valve block down with your thumb while tightening the four screws uniformly in a diagonal pattern. **Do not over tighten** the screws, this can cause the manifold to strip or the insert to come loose.
- 9) Continue these steps for all pneumatic valve blocks on both A and B side manifolds, including the B side water and disinfectant valve blocks.

MTK019INS REV A (04/19)

PNEUMATIC VALVE BLOCK EXPLODED VIEW

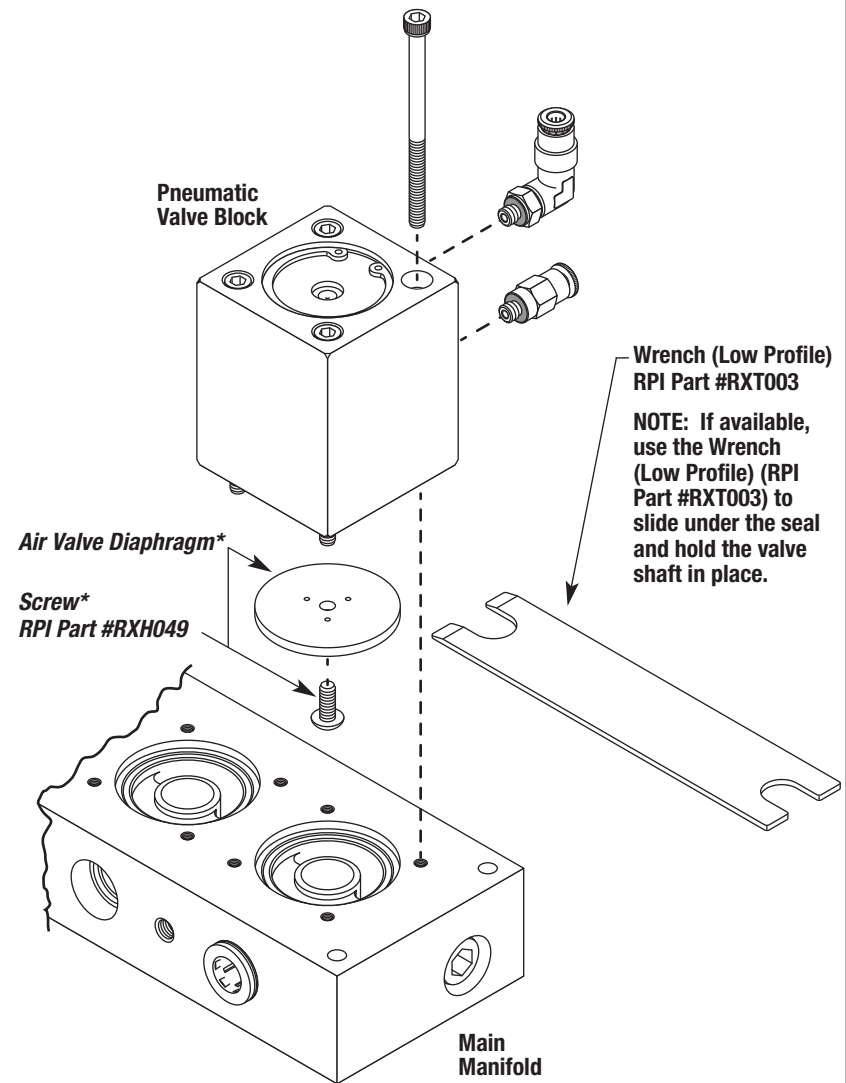

* Included in Air Valve Diaphragm Kit (RPI Part #MTK019)
with Retaining Compound 609 (RPI Part #RXA049)