

PERI-PRO (90000)

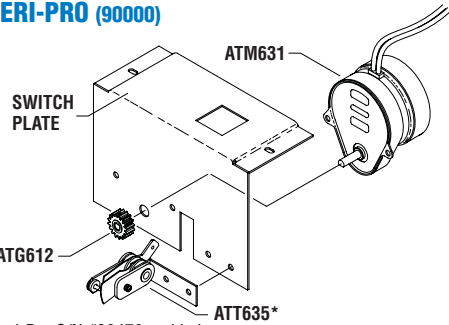

*Peri-Pro S/N #20479 and below

PERI-PRO (90000) & PERI-PRO II (91000)

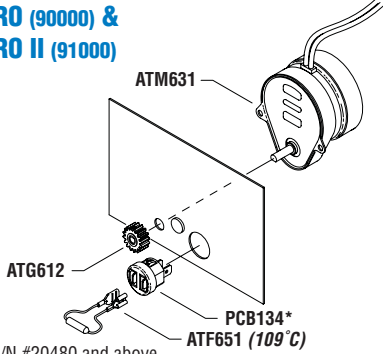

*Peri-Pro S/N #20480 and above

PERI-PRO III (94000)

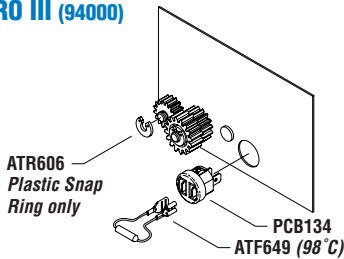

**HEATER & FUSES TO FIT AIR TECHNIQUES
PERI-PRO (90000), PERI-PRO II (91000)
& PERI-PRO III (94000)**

PERI-PRO III (94000)

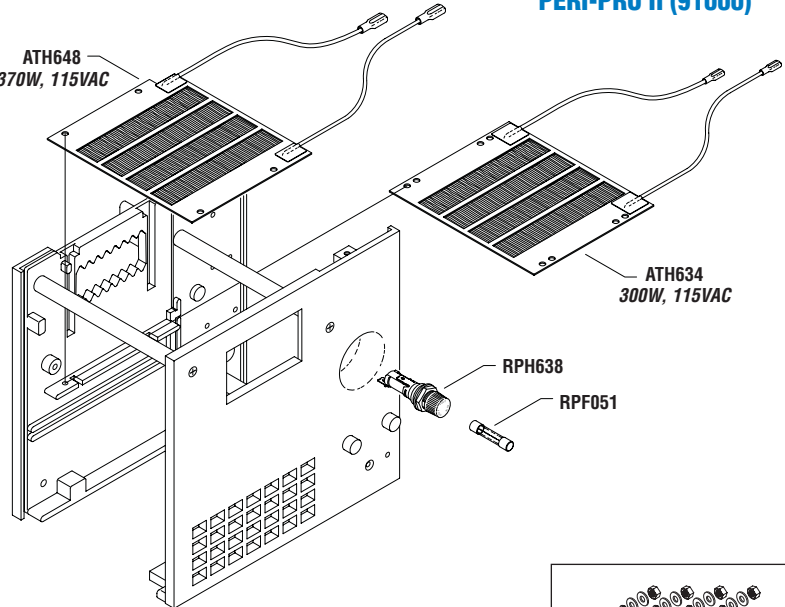

PERI-PRO (90000) & PERI-PRO II (91000)



Mounting Hardware included with Heating Elements (RPI Part #ATH634 & ATH648)

RPI PART #	OEM PART #	DESCRIPTION	PKG QTY	PERI-PRO			NOTES
				I	II	III	
ATF649	94278	THERMAL FUSE (98°C) <i>(Only fits Peri-Pro III)</i>	1			•	• Opens at temperature of 98°C • Fits: Terminal Bushing (RPI Part #PCB134)
ATF651	90278	THERMAL FUSE (109°C) <i>(Only fits Peri-Pro I & II)</i>	1	•	•		• Opens at temperature of 109°C • Fits: Terminal Bushing (RPI Part #PCB134)
ATG612	91993	DRYER DRIVE GEAR	1	•	•		• 16 teeth; .188" ID x .75" OD • Fits: Dryer Drive Motor
ATH634	90610	HEATING ELEMENT (DRYER)	1	•	•		• 300W; 115VAC; ~43.8Ω • Use with Thermal Fuse (RPI Part #ATF651) • Includes mounting hardware
ATH648	94630	HEATING ELEMENT (DRYER)	1			•	• 370W; 115VAC; ~35.5Ω • Use with Thermal Fuse (RPI Part #ATF649) • Includes mounting hardware
ATM631	90223	DRYER DRIVE MOTOR	1	•	•		• 115VAC, 60 Hz.
ATT635	90210	THERMOSTAT/BRACKET ASSEMBLY	1	1			• Opens at 165°F
PCB134	117327	ELECTRICAL TERMINAL BUSHING	1	2	•	•	• 3 per package • Mounts Thermal Fuse
RPF051	90265	FUSE (5A, 250VAC)	5	•	•	•	• Type: Glass; AGC Fast Acting • Size: 1/4" dia. x 1-1/4" lg.
RPH638	90219	FUSE HOLDER (MAIN)	1	•	•	•	• 3/16" quick connect tab • Accomodates standard 1/4" x 1-1/4" fuse • 20A@250VAC • Fits .50" dia. mounting hole • Includes mounting hardware

1 = Peri-Pro Serial #20479 and below

2 = Peri-Pro Serial #20480 and above



replacement parts industries, inc.

CALL (800) 221-9723 • FAX (818) 882-7028 • EMAIL order@rpiparts.com • WEBSITE www.rpiparts.com

The above parts are manufactured by Replacement Parts Industries, Inc. to fit Air Techniques equipment. All product names used in this document are trademarks or registered trademarks of their respective holders. WEB 02/09