



replacement parts industries, inc.

"The Alternate Source"®

CALL 800-221-9723 or 818-882-8611 • FAX 818-882-7028
E-MAIL: techsupport@rpiparts.com • WEBSITE: www.rpiparts.com

**ATK629
TRANSPORT REPAIR KIT TO FIT PERI-PRO® I & II
INSTALLATION INSTRUCTIONS**

INSTALLATION TIP

Use a pin punch or center punch to tap gears, shafts and bushings for removal or installation. To avoid damage to the transport while tapping these parts, support the underside of transport frame with several strips of wood in varying sizes (eg. 1"x1", 2"x2" and 2"x4") as needed.

1. Remove all gears and arms being held in place with the Plastic Snap Rings and set them aside for now. **See Figures 1 and 2 shown on the reverse side.**
Note: Be careful not to damage the "U" Transfer Arms (RPI Part #ATA618) because you will reuse them later in these instructions.
2. Place the open side of the transport down and support it with several strips of wood. Tap out the Shafts (RPI Part #ATS624) of the three largest Gears (RPI Part #ATG619). Set all of the gears and the shafts aside for now. **See Figures 1 and 2.**
Note: Be careful not to damage the Shafts (RPI Part #ATS624) because you will reuse them later in these instructions.
3. Tap out the three smallest gears (RPI Part #ATG613) and set the three "L" Transfer Arms (RPI Part #ATA617) aside for now. **See Figures 1 and 2.**
Note: Be careful not to damage the "L" Transfer Arms (RPI Part #ATA617) because you will reuse them later in these instructions.
4. Place the new Gears (RPI Part #ATG620) on the old Shafts (RPI Part #ATS624) from Step #2 above. Then place the new the Transfer Arm Bearings (RPI Part #ATB616) and Transfer Arm Gears (RPI Part #ATG615) onto the "U" Transfer Arms from Step #1. **See Figures 1 and 2.**
Note: Make sure that the bearings, gears and arm assembly are pressed tightly together.
5. Replace all six Bushings (RPI Part #ATB621) located on the top rows on both the front and rear sides of the transport. **See Figures 1 and 2.**
6. Replace all six Bushings (RPI Part #ATB622) located on the lower rows on both the front and rear sides of the transport. **See Figures 1 and 2.**

INSTALLATION TIP for STEPS #7-8

When installing all of the new gears and bushings, leave ~1/32" between each gear and bushing for proper play.

7. This step requires the three shaft and gear assemblies from Step #4. From these assemblies, select the one that has the longest shaft and install it into the RINSE WATER section of the transport. Place the large Gear (RPI Part #ATG619) onto the shaft while tilting the transport on its side and tap the shaft until it is flush. Place the new Speed Reducer Gear (RPI Part #ATG653) onto the same shaft while tilting the transport on its side and tap the shaft until it is flush. **See Figure 2.**

Place the large Gears (RPI Part #ATG619) onto the two remaining shaft and gear assemblies in the same manner as above and install one into the FIXER section and the other into the DEVELOPER section. **See Figure 2.**

8. Replace the three "L" Transfer Arms from Step #3 in the transport. **See Figure 1.** Place the three smallest Gears (RPI Part #ATG613) onto the old "L" Transfer Arm shafts from Step #3, lay the "gear" side of the transport facing down and tap the arms one at a time until almost flush.
9. Replace the three "U" Transfer Arms from Step #1 back into the transport. **See Figure 1.** Secure the arms by installing a new Plastic Snap Ring (RPI Part #ATR606).
10. Starting with the RINSE WATER section of the transport, align the new Idler Gear (RPI Part #ATG614) and both the "L" and "U" Transfer Arms in the horizontal position, then secure the gears by installing a new plastic snap ring. Repeat the procedure with the FIXER section and then the DEVELOPER section of the processor. **See Figure 1.**
11. Now open the bag included with this kit labeled "ATK628 – SHUTTER RELEASE REPAIR KIT", remove the installation instructions and begin at Step #1.
Note: Procedures on how to adjust the timing of the transport are addressed in the Shutter Release Repair Kit (RPI Part #ATK664) installation instructions.

FIGURE 2
PERI-PRO® I & II
TRANSPORT (REAR VIEW)

* Included in Shutter Release Repair Kit (RPI Part #ATK628)
 ** Included in Transport Repair Kit (RPI Part #ATK629) PLUS
 the Shutter Release Repair Kit is also include in this Kit!

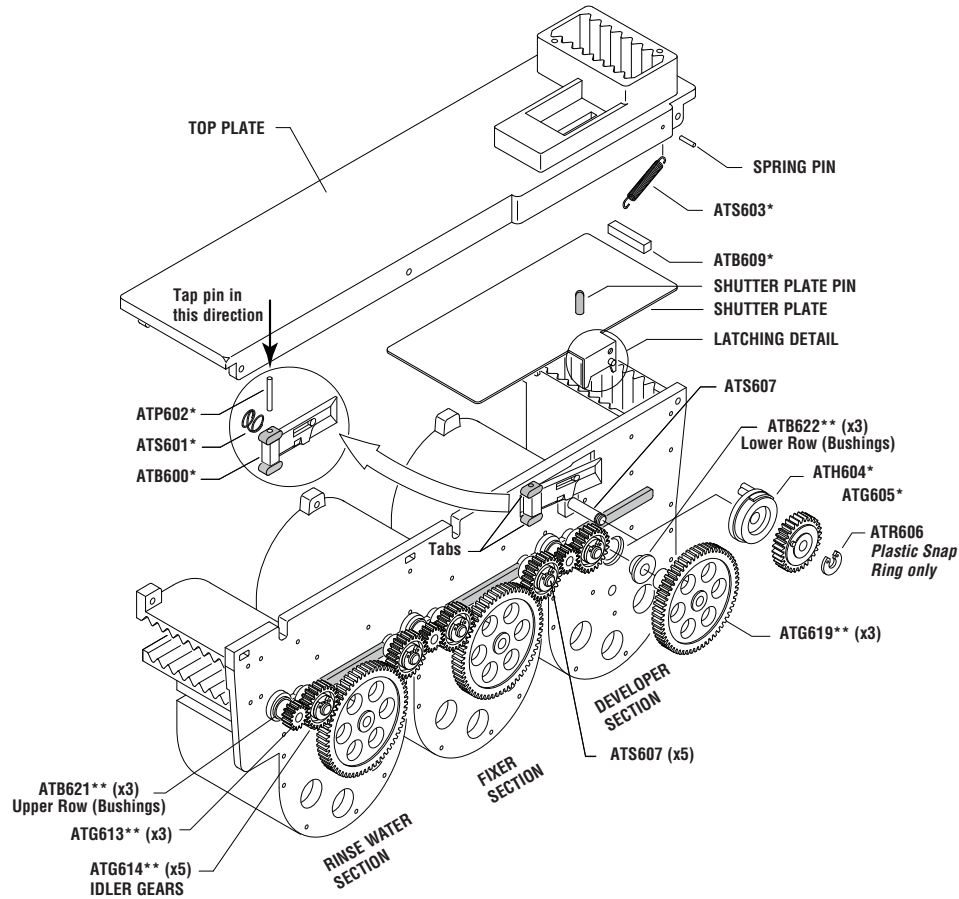
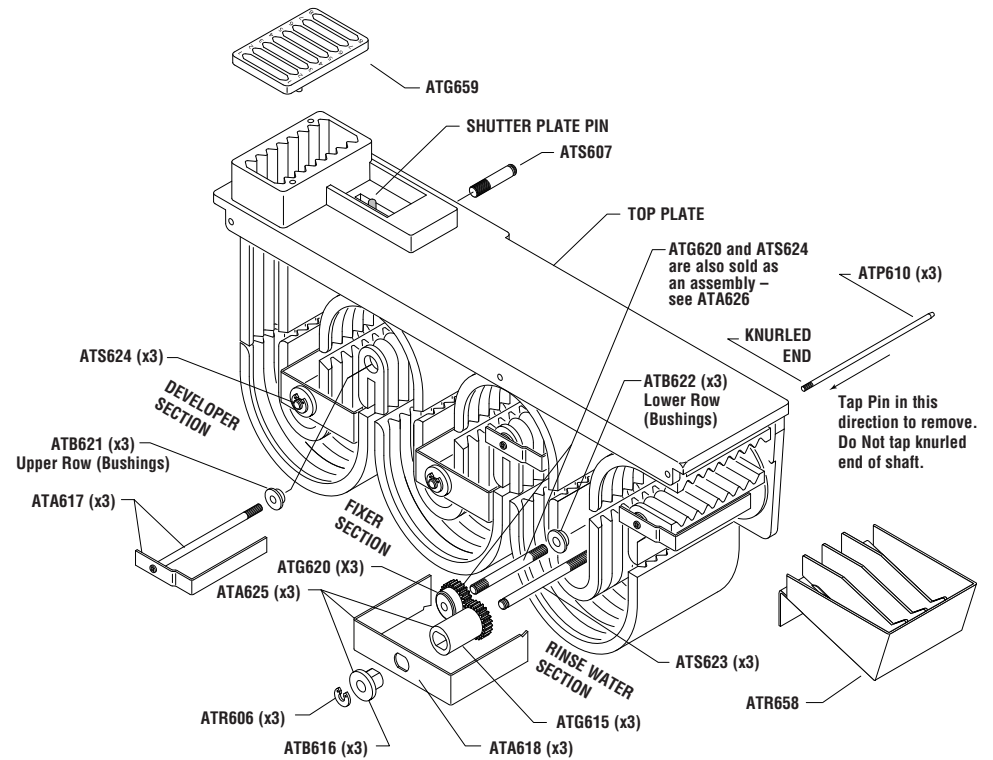

FIGURE 3
PERI-PRO® I & II
TRANSPORT (FRONT VIEW)

* Included in Shutter Release Repair Kit (RPI Part #ATK628)
 ** Included in Transport Repair Kit (RPI Part #ATK629) PLUS
 the Shutter Release Repair Kit is also include in this Kit!



ATK629
TRANSPORT
REPAIR KIT

	RPI PART #	DESCRIPTION	QTY
<input type="checkbox"/>	ATB616	TRANSFER ARM BEARING	3
<input type="checkbox"/>	ATB621	"L" TRANSFER ARM BUSHING	6
<input type="checkbox"/>	ATB622	TRANSFER ARM BUSHING	6
<input type="checkbox"/>	ATG613	"L" TRANSFER ARM GEAR	3
<input type="checkbox"/>	ATG614	IDLER GEAR	5

	RPI PART #	DESCRIPTION	QTY
<input type="checkbox"/>	ATG615	TRANSFER ARM GEAR	3
<input type="checkbox"/>	ATG619	TRANSFER ARM GEAR	3
<input type="checkbox"/>	ATG620	TRANSFER GEAR	3
<input type="checkbox"/>	ATK628	SHUTTER RELEASE REPAIR KIT	1
<input type="checkbox"/>	ATR606	PLASTIC SNAP RING	10